



RTFI257CTM401 - Antenne ATEX 450-470MHz Lighting arrestor TNC Plug to TNC Bulkhead Jack 0-6 GHz

Mode de protection:

Type de protection: II 2G Ex d IIB
 Classe de température: T6
 Température Ambiante : -20/+40°C
 Zones : 1-2

Description:

Antenne 450-470MHz pour les zones ATEX 1 & 2 (Gaz). Léger et compact, **coffret en acier inoxydable AISI316L** et corps de l'antenne en laiton nickelé. Puissance d'émissions max 2W. Presse étoupe M20 non armé **en acier inoxydable AISI316L**, kit joints 5.5-8 / 8-10.5 / 10.5-13 mm.

Connecteur TNC femelle.

Applications tels que réservoir de surveillance, plate-forme pétrolière, zone chimique, utilitaire de systèmes où présence de gaz.



Référence:

RTFI257 CTM401 – 0

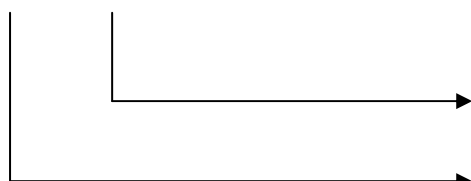

Longueur de câble

0 : sans câble
 5 : 5m de câble
 10 : 10m de câble
Autre longueurs sur demande

Antenne

450MHz à 470MHz

Modèle de boîte

RTFI257

RTFI257CTM401 450MHz à 470MHz

Approx height (mm):

Autres modèles sur demande:

RTFI257CTM800 Dual band 824-896 MHz & 1850-1990 MHz

RTFI257CTM801 Dual band 801-940 MHz & 1901-2000 MHz

RTFI257CTM900 902-928 MHz

RTFI257CTM5000 5.0 GHz

RTFI257CTM1500 1,575.42MHz

RTFI257CTM2400 2.4GHz

Spécification techniques antenne

Bandwidth: 450 MHz to 470 MHz

Impedance: 50 Ω

Gain: 0.0 dBi

Maximum power: 2 Watts

Connector type: TNC female

Mounting base: 20mm (M20)

7 joule impact rating

Weight: 1.06 lbs., 0.48 kg

Maximum length including TNC connector: 5.85",
 148.6mm

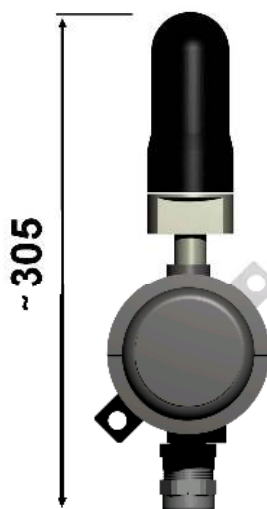



RTFI257CTM401 - Antenne ATEX 450-470MHz Lighting arrestor TNC Plug to TNC Bulkhead Jack 0-6 GHZ

Schéma:

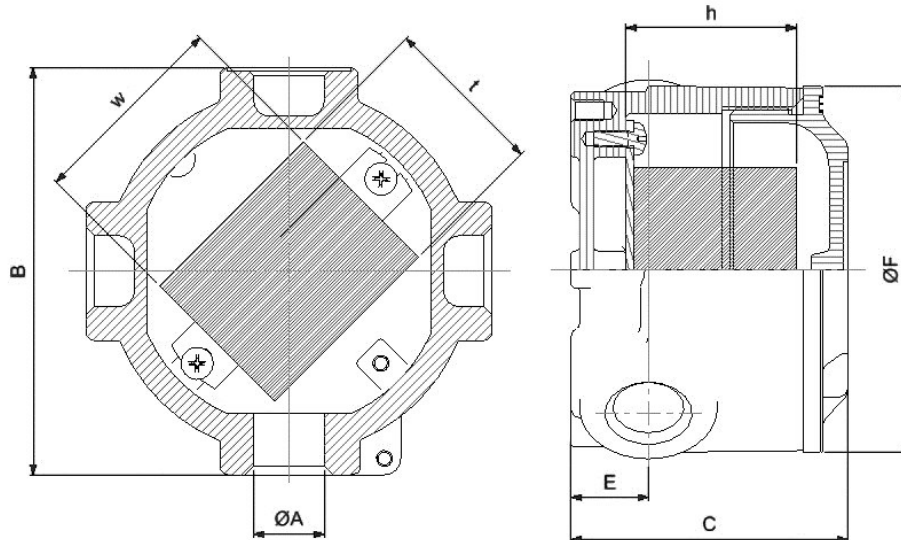

Boîtier	ØA	Dimensions externe (mm)					Dimensions interne (mm)			Volume elec. (dm ³)	Poids (kg)
		External dimensions (mm)					Internal dimensions (mm)				Weight (kg)
		B	C	D	E	F	h	W	t		
RTFI257CTM401	M20	126	82	11	24	112	50	65	45	0.146	2.20



Fixation	Dimensions (mm)						Poids (kg)
Bracket	A	B	C	D	E	F	Weight (kg)
KF7S	142	18	3	6.5	10	124	57

Exemple avec fourniture de câble





RTFI257CTM401 - Antenne ATEX 450-470MHz Lighting arrestor TNC Plug to TNC Bulkhead Jack 0-6 GHz

Lighting arrestor



Specifications	
Model	TW-LP-TNC-P-BHJ
Frequency Range	DC 0-6 GHz
Insertion Loss	.01dB/1GHz, .02dB/2GHz, .04dB/3GHz, .05dB/5GHz, 0.6dB/6GHz
VSWR	DC~6 GHz <1.5
Impedance	50 Ω
Connector	TNC Plug To TNC Bulkhead Jack
Operating Temperature Range	-86°F to 185°F
Dimensions	(L x W x H) 0.9" x 2.4" x 1.2"
Insulation Resistance	DC 100V More Than 50 MΩ
DC Discharge Voltage	90 V
Initial Impulse Wave Discharge Voltage	Less Than 700 V (1KV/μs)
Rated Impulse Wave Discharge	20 KA (Wave 8/20 μs) 10 Times (5 Times Each Polarity)
Weight	0.28 lbs
Ground Connection	By Feedthrough or Screw Terminal
Recommended AWG	18 AWG ground wire

